

# Solar Energy Basics

*for Homes and Businesses*

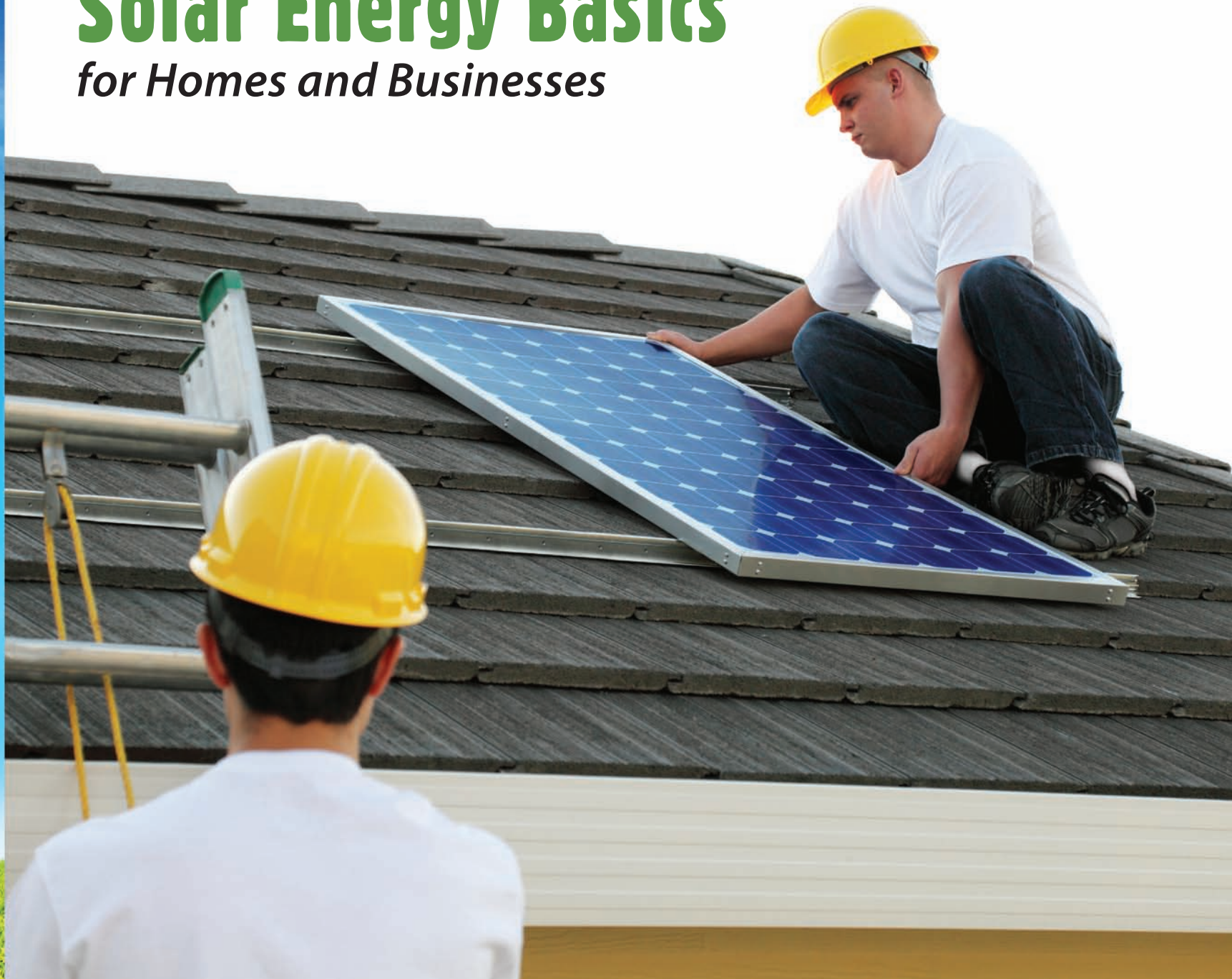



## Call Your Electric Cooperative First!

Before purchasing a solar system to generate electric power at your home or business, contact your local electric power association. Be sure to request a copy of the *Interconnection Agreement*. Solar thermal water heaters produce heat only and will not require an *Interconnection Agreement*.

Why does your local electric cooperative require an *Interconnection Agreement* for solar electric (photovoltaic) systems? When solar electric generation is connected to utility metered wiring at your home or business, it is interconnected to the national power grid. The United States Department of Agriculture Rural Utilities Service requires interconnection agreements for power generating equipment tied to funded rural electric systems. Failure to meet standards can create a serious safety hazard for owners, power line crews, and others.

Information from your local electric cooperative may be accessed through mapped links on the following website: <http://www.epaofms.com/ourMembers.aspx>.

Overview .....	1
Energy Efficiency First.....	2
Solar Q & A .....	4
System Types and Payback .....	8
Questions to Ask.....	12
Resources .....	Inside back cover

## Overview

Solar technologies allow us to harness the sun's energy for our immediate use. Solar energy can be stored as heat and the sun's light can be used to generate electric power for your home or business. Because the amount of solar radiation varies across our country, expectations of system performance should be based on location and orientation. This publication provides a basic overview of considerations. For serious solar decision-making, read the *Resources* section listed at the end of this publication and carefully select a qualified professional for assessing potential benefits. For your own safety and for the safety of our electrical line workers, call your local electric power association for interconnection requirements.

*Be sure to call before contracting the solar installation!*

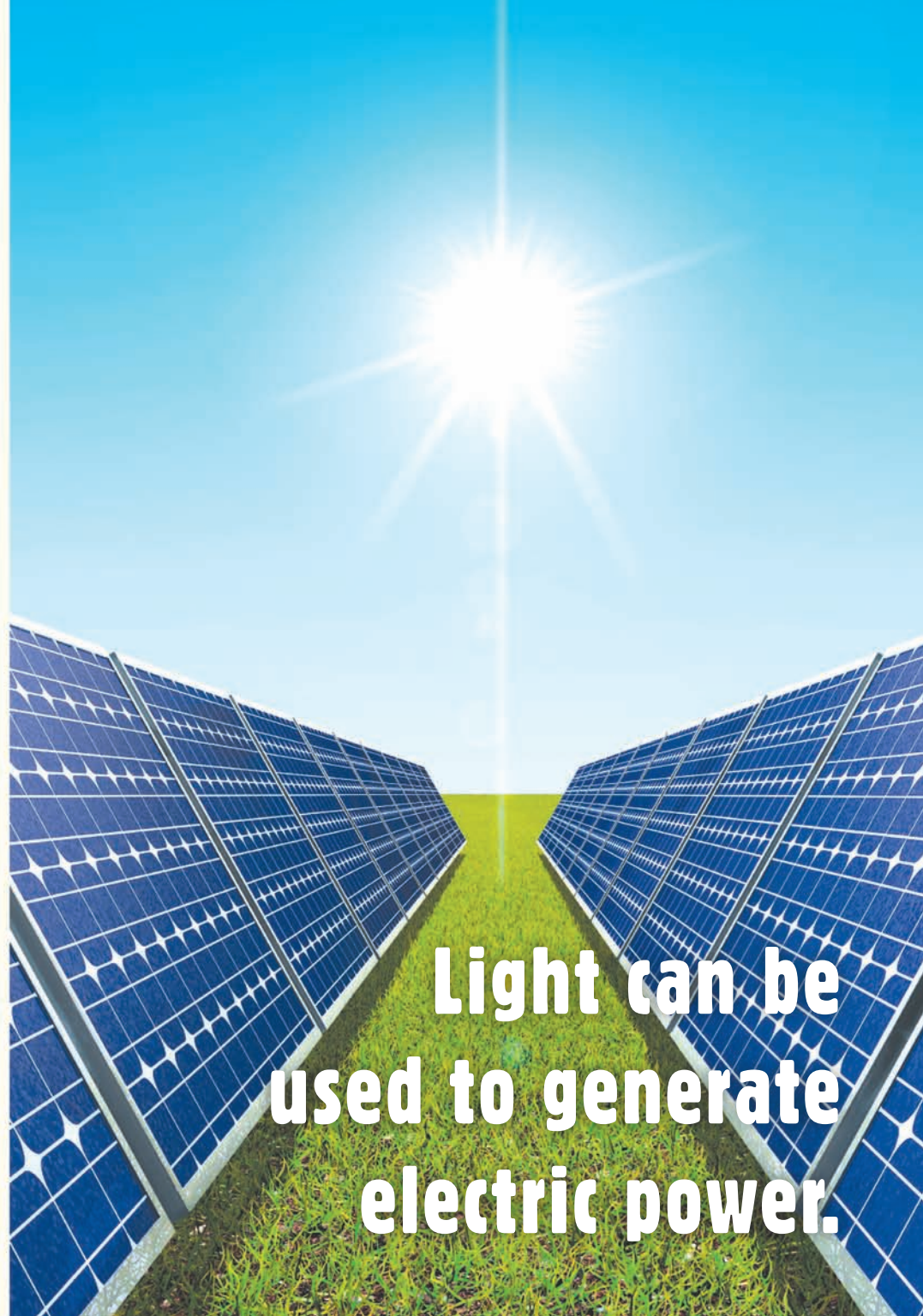

**Light can be used to generate electric power.**



# Energy Efficiency First

Achieving energy efficiency first can lower the size and cost of a solar installation. Investments in energy efficiency upgrades will most often result in faster payback as compared to solar power generation. Before evaluating solar energy for your home or business, make energy efficiency a priority.

## Household Efficiency Measures:

- Reduce leakage from air conditioning and heating ducts by having duct joints sealed with mastic. (MOST IMPORTANT!)
- Air seal and insulate your home envelope to ENERGY STAR® recommendations. (<http://www.energystar.gov>)
- Shade sunny windows from the outside during the summer to

reduce heat gain into the home.

- Before purchasing a heating/cooling system, assure proper sizing. Oversized systems are less efficient. Ask the heating/cooling contractor for a printout of the ACCA Manual J (or J8) load calculation.
- Purchase an ENERGY STAR® heat pump or geothermal system. A geothermal heating/cooling system will likely provide most of your hot water as a free bonus.
- Make sure that the return air filter grille is large enough. The return filter grille size for an average three-ton system should be around 600 square inches total or more. Replace disposable filters at least once a month or clean reusable ones.

## A Solid Investment: Efficiency Upgrades Offer Financial Benefits

Adopting the following 10 energy efficiency measures in a typical home yields nearly \$600 in annual bill savings, providing an average 16 percent return on investment.

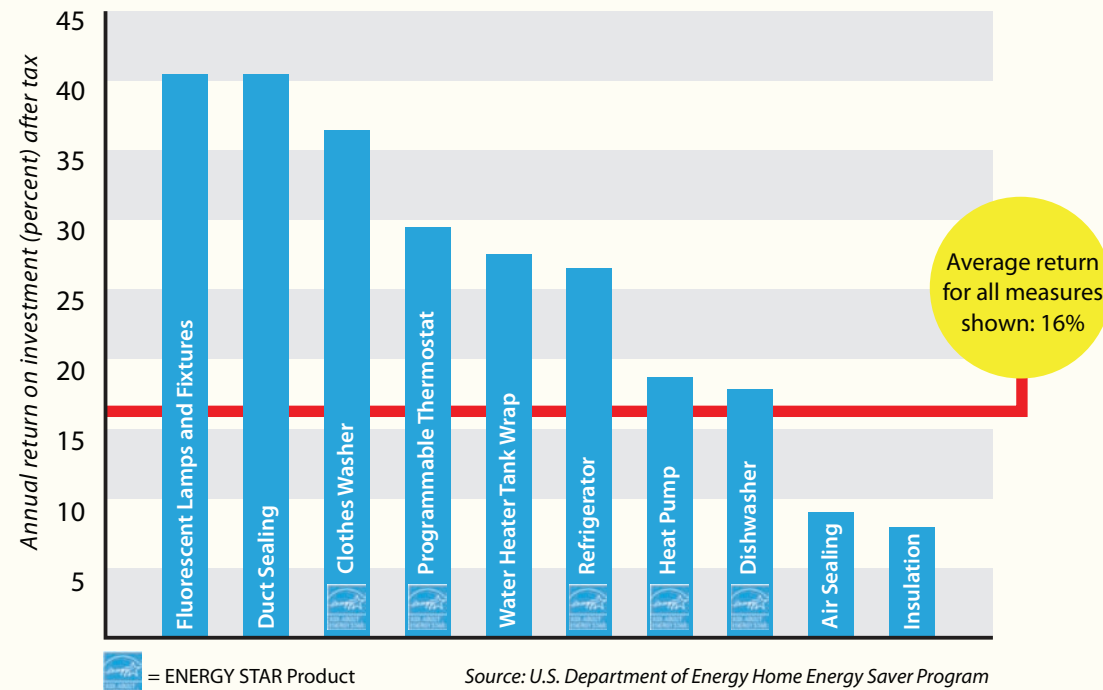

- Install an ENERGY STAR® programmable thermostat and learn to use it correctly.
- When replacing appliances, look for the ENERGY STAR® label.
- Use kitchen and bath exhaust fans for short times only to remove excess moisture.
- Insulate all accessible hot water pipes with pre-cut foam insulation sleeves.
- Repair all leaky faucets, pipes and water pumps. Install high-efficiency shower heads and low-flow faucet controls.
- Lower the water heater temperature setting to 120 degrees.

## Commercial Energy Efficiency:

Reducing the size of the total peak electrical load for your commercial facility is the first and most cost effective step in planning solar generation. Lighting is one of the largest users for commercial buildings, so upgrades are usually first order. Because lighting generates heat inside the building, lower lighting wattage saves energy for both lighting and cooling. Fluorescent T12 lighting can be replaced with more highly efficient T8 or T5 lighting. Lighting power density should be around .9 watts per square foot for most commercial applications and occupancy sensors should be installed where applicable. Energy efficient lighting technologies emerging into the market include LED lighting and induction lighting.

The total load reduction goal includes energy efficient equipment for heating/cooling, motors, water heating, lighting and other processes. Look for the ENERGY STAR® label and follow regular maintenance schedules. For more information, see <http://www.energystar.gov/> and select *Buildings and Plants; Guidelines for Energy Management; and Portfolio Manager Benchmarking Starter Kit.*





# Solar Q & A

## What exactly is solar energy?

Like the air we breathe, solar energy from the sun surrounds us every day. We have always enjoyed the sun's life-giving benefits of warmth and light. However, with today's improved technologies, solar energy can be harnessed for specific uses inside homes and businesses.

## How can solar energy be used?

- Sunlight can be converted into electricity.
- Sunlight can be captured for use as indoor lighting.
- The sun's heat energy can be used for water heating, space heating, or even pool heating.

## What types of on-site solar systems are there?

- Photovoltaic (PV) systems produce electricity from the sun's light energy. Photovoltaic solar panels are typically placed on the roof.
- Solar thermal systems use solar collectors, typically on the rooftop, to transfer the sun's heat energy for water heating and space heating.
- Passive solar design consists of a combination of building features to reduce or occasionally eliminate the need for cooling, heating and lighting.
- Now emerging into the market are PV roofing shingles and solar laminate materials made possible by thin film solar technology. These are classified as building integrated photovoltaics (BIPV) and give the appearance of standard construction features.

See *System Types and Payback* section for more information on each.

The map right, from the *National Renewable Energy Laboratory*, illustrates the annual availability of solar energy throughout our nation.

## Where can solar energy be used?

The U.S. Department of Energy defines renewable energy resources, including solar, as those that "are naturally replenishing but flow-limited." The availability, or flow, of solar energy varies greatly according to geographical areas of our country.

A solar electric installation in the state of Arizona will generate more electric power annually than the same solar installation in the state of Mississippi. Because there is less solar radiation in our state, a larger installation would be necessary to match the same amount of electric output. As a result, the cost of a solar power installation is higher in our state.

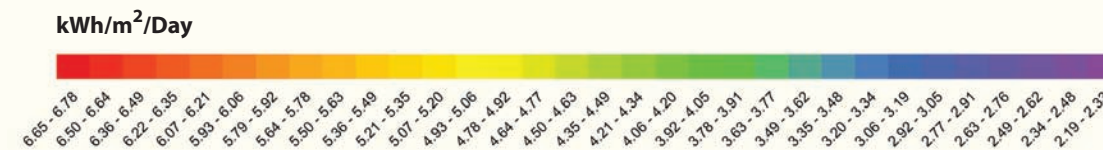
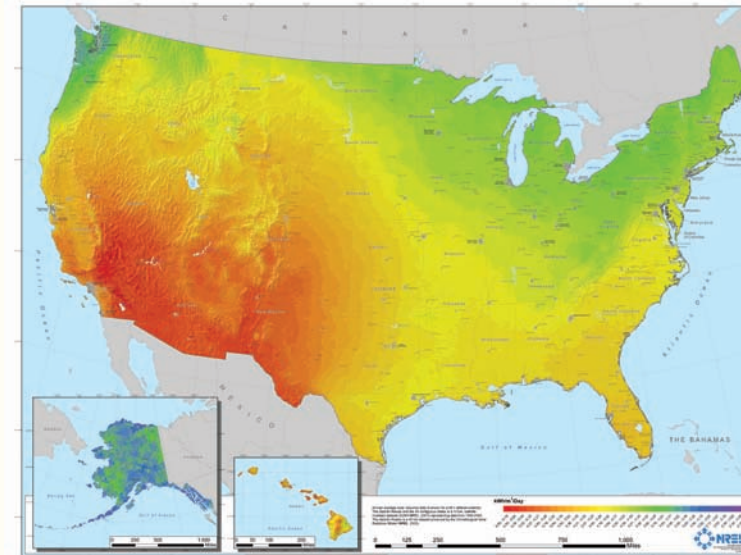

## How much do solar systems cost?

The total installed cost of solar PV power generation systems nationally ranges from approximately \$6 to \$10 per watt, not including federal tax credits. The larger the system, the lower the cost per watt will be and new home systems tend to be around 60 cents per watt lower in cost. Battery back-up will also influence pricing. Commercial systems sized around 8 kW or more will cost less per watt. Advancements in solar technology and mass production are expected to lower future costs and hasten payback on PV solar system investments.

A solar thermal water heater for a family of three to four may cost around \$5,000 to \$8,000 before the federal tax credit is applied. Cost and payback for solar water heating ranges from around 4 to 10 years depending on the system type, system size, hot water use, and costs. Labor costs vary.

## Is there a solar tax incentive for homeowners?

The American Recovery and Reinvestment Act of 2009 (Stimulus Bill) provides a homeowner tax credit for 30% of the PV solar system cost. The system must meet applicable fire and electrical code requirements. This credit, to be filed on IRS Form 5695, will be in effect until Stimulus Bill funds for this purpose are depleted.

## A thirty percent credit also applies to solar thermal water heating systems.

- Solar water heating for a pool or hot tub is excluded.
- The water heating system must be certified by the Solar Rating Certification Corporation or other comparable government endorsed entity.
- At least half of the water heating must be solar energy.

As energy costs rise, the value of any solar energy also increases.



# Q & A continued

## Is there a solar tax incentive for businesses?

- A business solar investment tax credit may apply for 30% of the initial PV installation expenditures (IRS Form 3468).
- A five-year accelerated renewable energy property depreciation allowance (IRS Form 4562) may result in faster payback on PV investments.

## Is financing available for solar systems?

Solar renewable and energy efficiency projects are typically financed through home equity loans or home improvement loans. The US Environmental Protection Agency provides financing for solar thermal and solar photovoltaic systems in an ENERGY STAR® home or building if a 10-year payback is demonstrated. Other loan programs are available through Fannie Mae Corporation, the U.S. Department of Agriculture, the Federal Home Mortgage Corporation, and the U.S. Department of Energy. The Small Business Administration also has a loan program for commercial solar installations.

## What are the first steps for considering a solar system?

Even solar system installers agree that energy efficiency should be the first priority before considering solar systems. Here are the first steps:

- Read Energy Efficiency First and reference *Resources* on the last page of this publication.
- Apply needed energy efficiency measures.
- Estimate the square footage of any south facing rooftop area or other area that receives hours of direct sunlight every day.
- **CALL YOUR LOCAL ELECTRIC POWER ASSOCIATION.**
- For solar PV generation, ask to speak to the cooperative's distributed generation representative about an interconnection agreement.
- For solar thermal (hot water), ask to speak to an energy efficiency advisor. Ask about how to find listings for SRCC certified equipment.

- Read about solar by checking out *Resources* on the last page of this publication.

Be sure to ask your cooperative representative about insurance requirements and responsibilities for service and maintenance.

## How is solar energy delivered?

The national electric power grid is the superhighway of power lines used for delivering electricity in our nation.

Solar systems that are connected to the grid deliver power through electrical wiring in your home or business. Typically, most of the solar power generated is used at that same location. Any remaining solar power is usually exported to the electric grid. Some solar installations have back-up batteries, which add around 30% to the cost of the installation.

Solar systems that are not connected to the electric grid deliver the sun's heat or light energy to the need inside the home or business.

## Are PV solar systems interconnected to the grid?

Typically, photovoltaic (PV) systems that serve various power needs are connected to the metered electric wiring network inside the home or business. That on-site interconnection links your solar electric system to the cooperative's power lines and to the national power grid. Connecting solar PV generation to the wiring inside your home or business is very different from connecting a major electric appliance. For safety, there are national standards that apply to interconnection.

## Can I use solar energy to "get off the grid" completely?

Generally, those who use on-site solar PV as a sole source of power, do so because they reside far from existing power lines. For these installations, PV can be a cost effective alternative to avoid the cost of a very remote power line connection. Most of these non-grid systems have a battery back-up for times when the sun is not shining.

## What are the reasons to interconnect my solar system?

Since PV energy production depends on sunshine, a typical solar installation will need access to the electric power grid on a daily basis for the supplementary energy needs. If your PV system generates more power than you use, the additional energy can be sold back to the power provider at their avoided cost. Any PV system that connects to the metered electrical wiring in your home or business is interconnected to the grid, and requires an interconnection agreement.

## Why is an interconnection agreement required?

The USDA Rural Utilities Service requires interconnection agreements for consumers to interconnect generation. These agreements are a means of assuring safety, reliability and quality of electric service for all. Even national security is tied to the reliability of our national electric power grid.

For all of these reasons, certain equipment requirements and work quality standards must be met within electric cooperative service territories. If one line worker is unaware of power generating equipment in the area when repairing electric power lines, the results can be deadly. For family and community safety, be sure to call your electric cooperative about an interconnection agreement prior to installing solar PV systems.

## Who determines the interconnection requirements?

Electric cooperative requirements for interconnection are based on standards established by the Institute of Electrical and Electronic Engineers (IEEE) and Underwriters Laboratory (UL).

## Which types of solar systems are NOT connected to the grid?

Solar systems that do not produce electricity are solar thermal water heating systems or solar light pipes. These systems use the sun's heat and light energy, but are not connected to the grid.

## Examples of stand-alone solar electric items that are not connected to the grid include:

- Solar stake light for sidewalks
- Solar garage light (dedicated wire)
- Solar powered attic ventilator
- Solar powered livestock watering pump
- Gate opener

Stand-alone solar electric items are purchased as kits at home improvement stores and consist of a small solar PV cell, a battery, and one item to be powered directly.

## How should I select an installer?

As with any technology installer, the most important considerations for selection are:

- Training
- Certification
- Experience
- Word of mouth recommendations

The North American Board of Certified Energy Practitioners provides national certification for installers in the field of renewable energy. The number of certified solar photovoltaic installers and solar thermal installers is limited but growing. See *Resources on the last page of this publication*.

All PV system installations must be certified by an approved certifying agent before interconnecting to the electric grid. See *the electric cooperative interconnection agreement for the details regarding interconnection certification requirements*.

# Solar System Types and Payback

## Photovoltaic (PV) Systems

The word "photo" means light. "Voltaic" relates to electric current. Photovoltaic (PV) technology uses the sun's light energy, not heat, to produce electricity.

### How does it all happen?

Solar PV cells are the basic building blocks. The semiconductor material that makes up a solar cell is similar to a computer chip. When high energy solar rays strike the surface of a PV cell, electrons begin to move and electricity is generated. These are the same solar rays that cause sunburn, but now they can do something amazing!

When connected, PV cells form a PV module or panel. If modules are connected, the grouping is called a solar array. Some photovoltaic cells are integrated into building materials, so that they are not visible. Roof shingles and glass can contain PV material that acts like a solar module.

The inverter converts the direct electric current (DC) produced by the PV system to alternating current (AC). Alternating current is compatible with the grid and your home appliances. Some PV systems have a battery used to store excess energy to supplement when the sun is not shining.

At the present time, the average PV efficiency of turning solar energy into electric power runs around 12%. When technology advances result in greater efficiency, then payback on consumer dollars will be faster. That new technology is in the works!

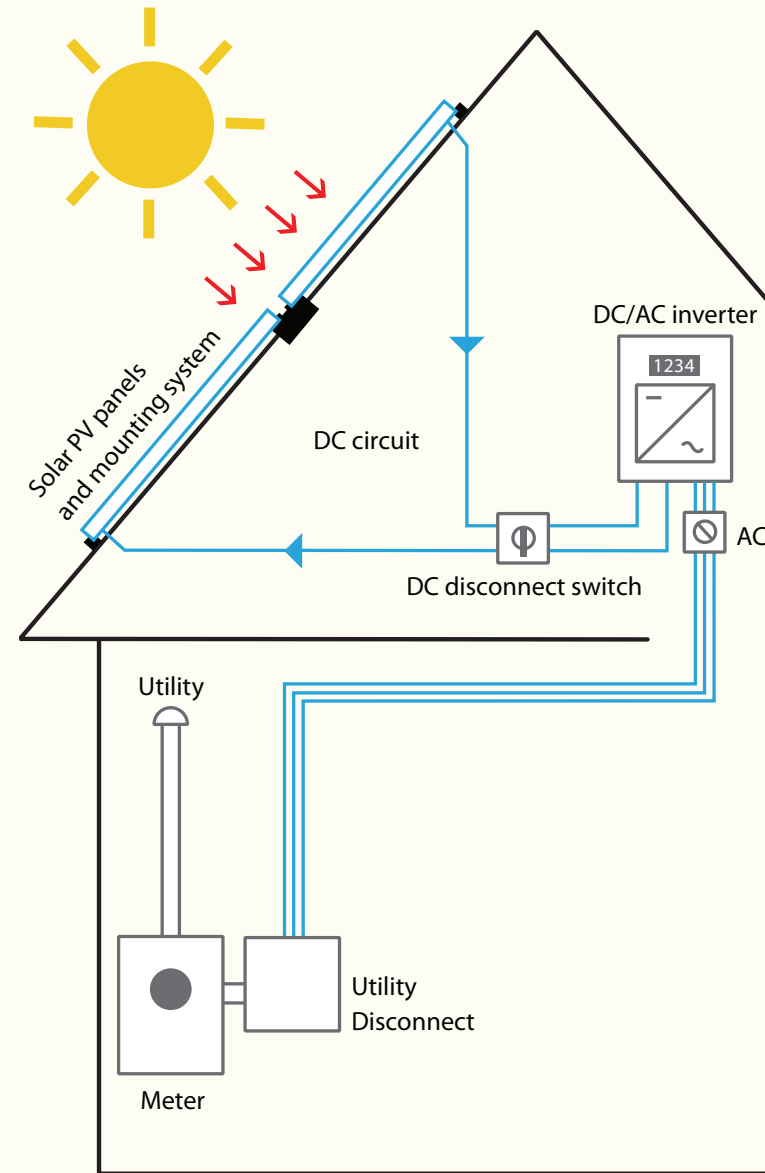

## Quick Estimate of PV Cost

1. Determine the square footage of available south-facing roof area.
2. Multiply square footage x 10 to get watts.
3. Multiply watts x \$6 to \$10 to get a ballpark total installed cost.

## Cost and Payback

With numerous solar PV calculators on the web, there are some differences in calculating payback. See Resources. Note that some calculators give credit for increased real estate value as a result of the installation.

For an all-electric home averaging around 1350 kWh per month, a 3 kW PV system would produce about 25% of the total energy used by the home.

### Example 3 kW PV System

Producing approximately 25% of energy;

Source.....	<a href="http://www.solar-estimate.org">http://www.solar-estimate.org</a>
Prior Home Usage.....	1350 kWh; \$158 per month
System Size.....	3.1 kW DC
Roof Area.....	307 square feet
Approximate Total Cost.....	\$27,630
Federal Tax Credit (if applicable).....	\$ 8,289
Net Cost.....	\$19,341 (after applicable tax credit)
Payback.....	23 years

This example assumes that all power generated is used at the same home location. Any excess power can be sold back to the power supplier at avoided cost. Break-even points for payback vary with cost of utility power, inflation rate, system orientation to the sun, system cost, financing, and tax bracket. This web calculator assumes an \$8,425 increase in home resale value for this 3 kW system. For interconnected PV calculations at <http://www.solar-estimate.org>, energy cost entered should be cost per kWh after any base charge is applied.



Photovoltaic (PV) technology uses the sun's light energy.



# Types and Payback continued

## Solar Thermal Water Heating

Solar thermal systems collect and transfer the sun's heat energy, with the most common uses being domestic water heating and pool heating. For a warm touch on cold winter mornings, water heated by a solar collector on the roof can be piped under floors for space heating too! There is no electric power produced by this type of system.

The plus side of solar thermal is that it is much more efficient at using the sun's energy when compared to PV. Greater efficiency along with a lower initial price tag means a much faster payback for consumer dollars invested.

The device that absorbs the sun's heat energy is a solar collector. Like a PV module, it can be placed on a roof or on a support structure. Before sizing your solar water heater and collector, find ways to reduce your overall hot water consumption. Install low flow shower heads, faucet aerators, and an ENERGY STAR® washer and dishwasher. *See the Solar Rating Certification Council website listed in Resources.*

### Types of Solar Water Heating Systems: Passive and Active

A passive solar water heating system is the simplest, least cost system. It is somewhat less efficient, but has no pumps or controls for maintenance worries. These systems will operate during a power outage.

Active systems use electric pumps, valves, and controllers to move water or an antifreeze solution, through collectors. This is the most common type of solar water heater in the United States, but it will not operate during a power outage unless pumps have backup power. A drainback system that uses water for heat exchange is the most simple type of active system.

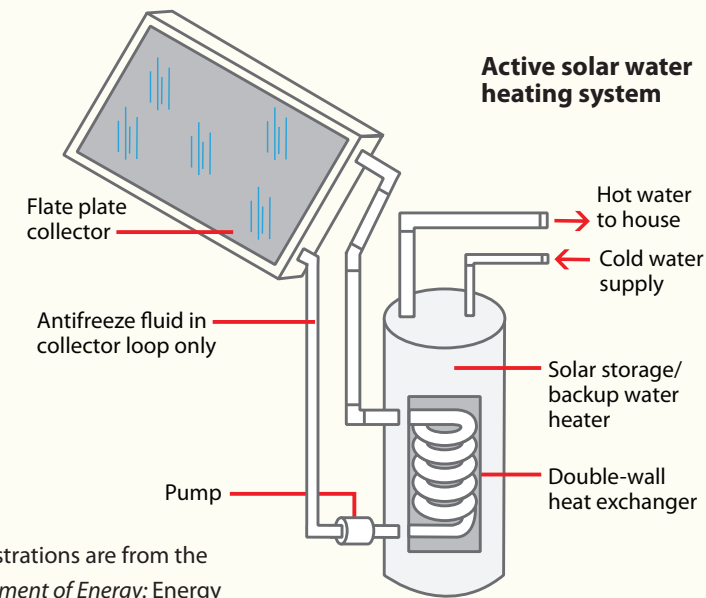
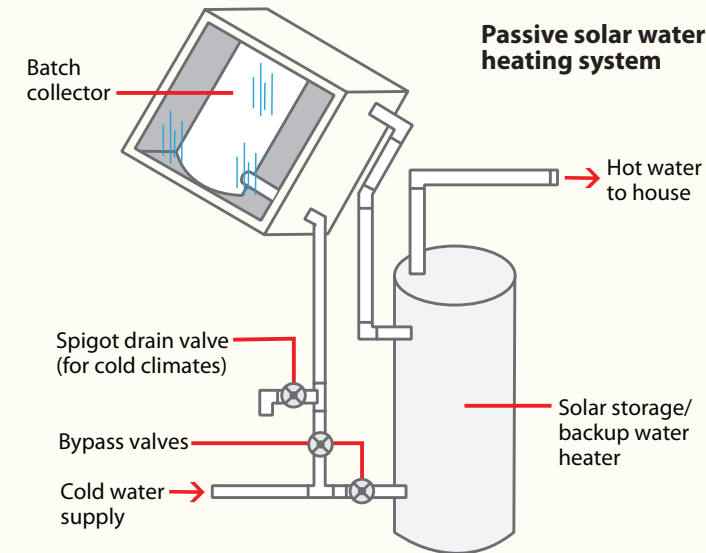

These illustrations are from the US Department of Energy: Energy Efficiency & Renewable Energy

## Water Heater Sizing

To determine broad sizing estimates for the storage tank and the collector, see guides below. However, rely on a qualified professional to determine the correct size for your household or business.

### Minimum Residential Solar Tank Size

1-3 people .....	50 to 60 gallon tank
3-4 people .....	80 gallon tank
4-6 people .....	120 gallon tank

### Typical Collector Size (to meet nearly all hot water needs)

First 2 people .....	20 square feet for each
Additional people .....	8 square feet for each

Experts suggest that for active systems, there should be at least 1.5 gallons of storage to every one square foot of collector area. This is to prevent overheating when the demand for hot water is low.

### Solar Water Heater Payback Example

Source .....	<a href="http://www.solar-estimate.org">http://www.solar-estimate.org</a>
Location .....	near Hattiesburg, MS
People .....	3-4
Solar Collectors .....	2
Tank Size .....	80 gallons
Annual Energy Saved .....	4688 kWh
Approximate Total Cost .....	\$6,000
Federal Tax Credit .....	\$1,800
Net Cost .....	\$4,200
Payback (assuming increase in property value) .....	5-6 years

Calculation assumes an active system. For water heating calculations at <http://www.solar-estimate.org>, energy cost entered should be cost per kWh after any base charge is applied. System cost and payback will vary according to system type and hot water usage patterns.

## Passive Solar Design

Passive solar design is the most economical way to use the sun's energy. Many homes and buildings are designed to take advantage of solar resources for use as heating and natural lighting. Passive design integrates building features to reduce the need for heating, cooling, and daytime artificial lighting

**Heating and Cooling:** Since the south side of a home or building receives the most solar heat, passive design uses large south-facing windows for heating. To avoid the additional heat gain in summer, the overhang on the same window is sized according to latitude. This provides shading from the high summer sun, while allowing the winter sun to shine in at a lower angle for heat and light. Landscaping helps south, east, or west facing windows avoid summer heat gain. Deciduous trees, those that lose their leaves in winter, allow winter sunlight to pass through while shading in summer. *See Resources for overhang sizing.*

**Daylighting:** Daylighting is the practice of architectural design for maximum use of daytime sunlight. Levels of electric lighting can be adjusted to accommodate available natural light. Solar light pipes or light tubes transport the sun's light from the roof to the desired indoor location.

For commercial buildings, schools, and other institutions, daylighting has been proven to increase worker productivity, patient health, and students' grades. There is also potential for energy savings, by decreasing the amount of heat otherwise produced by artificial lighting.

Windows with a high VT rating (visible transmittance) allow more light into the building or home. Glass VT ratings range between 0 and 1 with the higher numbers being best for using the sun's daylight. Glass with a low SHGC rating will reduce solar heat gain and lower cooling needs. For more information on passive solar design and glass ratings, *see Resources.*

# Questions to Ask

## “Off the Grid” No More Energy Bills?

How many solar panels would it take to supply all of my home power needs, so that I could disconnect from the cooperative power lines? Of course the answer varies for each household according to usage patterns, orientation to sun angle, energy cost, equipment efficiency, and installation type.

### Payback (off the grid) Example:

Source.....	<a href="http://www.solar-estimate.org">http://www.solar-estimate.org</a>
Prior Home Usage.....	1350 kWh; \$158 per month
System Size.....	12.13 kW DC
Roof Area Needed.....	1,229 sq. ft.
Estimated Installed Cost.....	\$110,610
Tax Credit (if applicable).....	\$33,183
Cost after Tax Credit.....	\$77,427
Payback (cash vs. loan).....	26 years

*Solar-estimate.org*, assumes a \$37,000 increase in home value for this 12.3 kW installation. If this appreciation in home resale value does not apply, the payback period will be significantly longer. For these homes NOT connected to the utility electric grid, adequate battery back-up may add significantly to cost. Solar materials cost varies over time.

### Ask Your Solar Dealer/Installer:

1. May I see the specification sheet for the solar panels?
2. What is the minimum warranted power? This is the amount of power generation guaranteed from a solar panel.
3. What are the STC\* and PTC\*\* ratings?
4. For how many years is the power production warranty?
5. What is the solar module efficiency in watts per square foot? (not cell efficiency)
6. What is the efficiency rating of the inverter? Purchase a high efficiency inverter for more power production.
7. Are the PV panels and inverter UL listed? Does the the inverter have UL 1741 certification for interconnection?
8. Does the manufacturer’s label on the mounting system state medium to heavy duty (or a hurricane mounting kit)?  
*See PV Ratings listed under Resources.*

*\*STC, the standard test conditions rating, represents the number of watts produced. It is typically displayed within the manufacturer’s model number on the module nameplate. Standard test conditions are a constant 78 degrees Fahrenheit.*

*\*\* PTC test conditions represent watts produced under varied realistic weather conditions. When PV module temperatures increase, the amount of electric power production decreases. PTC watt ratings will be lower than STC watt ratings. (The source for PTC testing is Photovoltaics for Utility Scale Applications (PV-USA).)*

Notes: \_\_\_\_\_  
\_\_\_\_\_  
\_\_\_\_\_  
\_\_\_\_\_  
\_\_\_\_\_

# Resources

**Energy Efficiency Savings and Home Energy Audit**  
<http://www.touchstoneenergysavers.com/homeAudits.html>

**Energy Efficiency: Home Energy Savings Handbook**  
[http://www.smepa.coop/news/smepa\\_energy\\_guide.pdf](http://www.smepa.coop/news/smepa_energy_guide.pdf)

**Energy Star®**  
<http://www.energystar.gov/>

**Economics of Solar Systems – Payback Calculator**  
<http://www.solar-estimate.org>

**Florida Solar Energy Center**  
<http://www.fsec.ucf.edu>

**Renewable Resource Data Center**  
(Click on Solar; Models and Tools; PVWatts)  
<http://www.nrel.gov/rredc/>  
<http://www.nrel.gov/gis/solar.html> (map of U.S. PV solar radiation)

**Portal for the solar industry**  
<http://www.solarbuzz.com>

**U.S. Department of Energy – Energy Efficiency and Renewable Energy**  
<http://www.eere.energy.gov>

**Applied Products and Building Research**  
<http://www.toolbase.org>  
Search for “solar”

**Federal Tax Incentives**  
<http://energytaxincentives.org>

**PV Ratings**  
<http://solar.calfinder.com/blog/solar-information/solar-panel-ratings-breakdown/>

**Solar Rating Certification Council (rates solar water heaters)**  
<http://www.solar-rating.org>

**Daylighting**  
<http://www.daylighting.org>  
[http://www.nfrc.org/documents/Daylighting\\_consumers.pdf](http://www.nfrc.org/documents/Daylighting_consumers.pdf)

**Windows and Overhang Sizing**  
<http://www.nfrc.org>  
<http://www.susdesign.com/overhang/>

**Passive Solar Design Technology Fact Sheet and Solar Road Map**  
<http://www.southface.org>

**Financing Solar Systems**  
<http://www1.eere.energy.gov/solar/pdfs/26242.pdf>

**Solar Contractor Locator**  
<http://www.findsolar.com>

**North American Board of Certified Energy Practitioners**  
<http://www.nabcep.org>

Visit these  
resources  
online.





This institution is an equal opportunity provider and employer.

